

**APPLICATION FOR DRIVEWAY APRON PERMIT**

DATE: \_\_\_\_\_ PERMIT #: \_\_\_\_\_ FEE: \_\_\_\_\_

NEW: \_\_\_\_\_ RELOCATION: \_\_\_\_\_ REPLACEMENT: \_\_\_\_\_

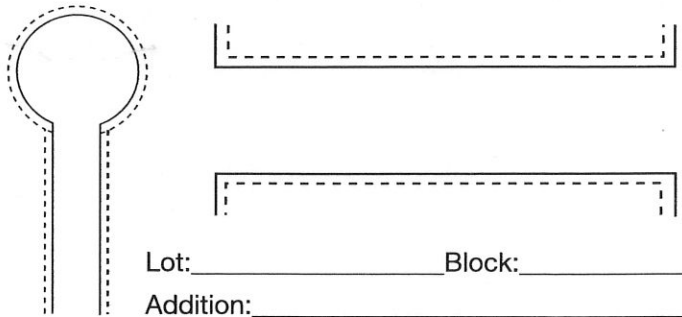

Lot: \_\_\_\_\_ Block: \_\_\_\_\_  
 Addition: \_\_\_\_\_  
 Address: \_\_\_\_\_  
 Owner: \_\_\_\_\_

Inspected by \_\_\_\_\_ Date \_\_\_\_\_

- ① 1/2" EXPANSION JOINT.
- ② CONSTRUCT APRON OF 6" CONCRETE PAVEMENT, Mn/DOT SPEC. 2301. DESIGN MIX NO. 3A32
- ③ CONTRACTION JOINT.
- ④ DRIVEWAY NEED NOT BE POURED MONOLITHICALLY WITH CURB AND GUTTER.
- ⑤ END FULL CURB SECTION.
- ⑥ BEGIN GUTTER SECTION.
- ⑦ WIDTH AT BACK OF APRON = 24' CMAX (32' MAX CURB)

It is expected we will begin construction on \_\_\_\_\_  
 and complete restoration on \_\_\_\_\_

SAW CUT NEW APRON STREET TRANSITION

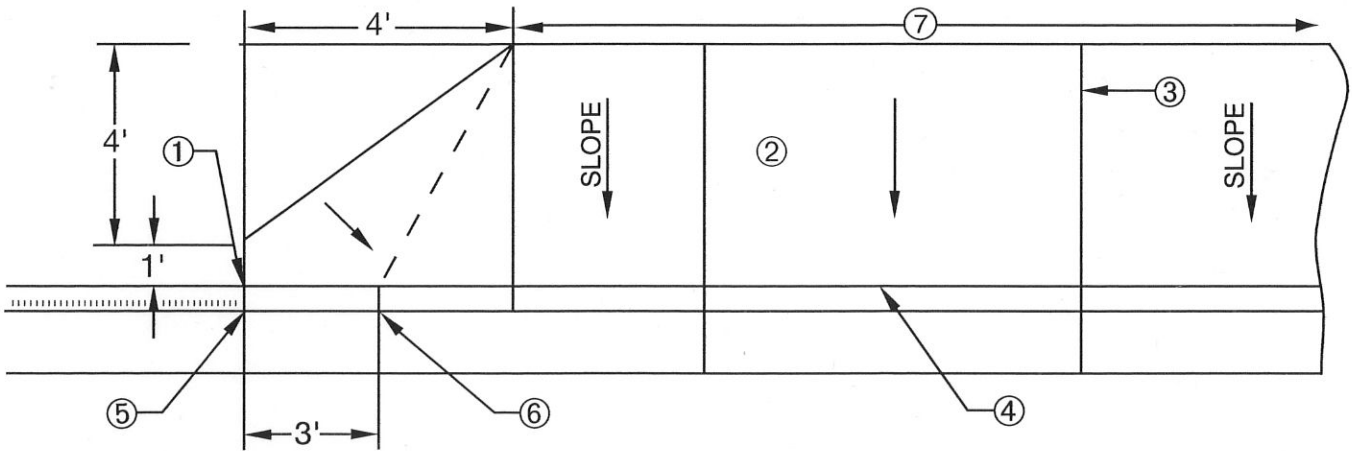

CURB MUST BE INSPECTED BEFORE CONCRETE IS POURED. INSPECTORS REQUIRE 24 HOUR NOTICE.

**If any utility is hit, please contact  
 City Hall immediately!**

**CITY OF SARTELL, MINNESOTA**

125 Pine Cone Road  
 (320) 253-2171

Applicant: \_\_\_\_\_  
 (Type or print clearly)

Address: \_\_\_\_\_

By: Name: \_\_\_\_\_  
 (Type or print clearly)

Signature: \_\_\_\_\_

Date: \_\_\_\_\_

Dated: \_\_\_\_\_

Received By: \_\_\_\_\_

Billing Inspector